

REVISIONS					
REV.	DESCRIPTION	D.C.P.	DATE	DRAWN BY	VERIFIED BY
1	FOR DISTRIBUTION	-	09/04/20	GMASON	KSTORER

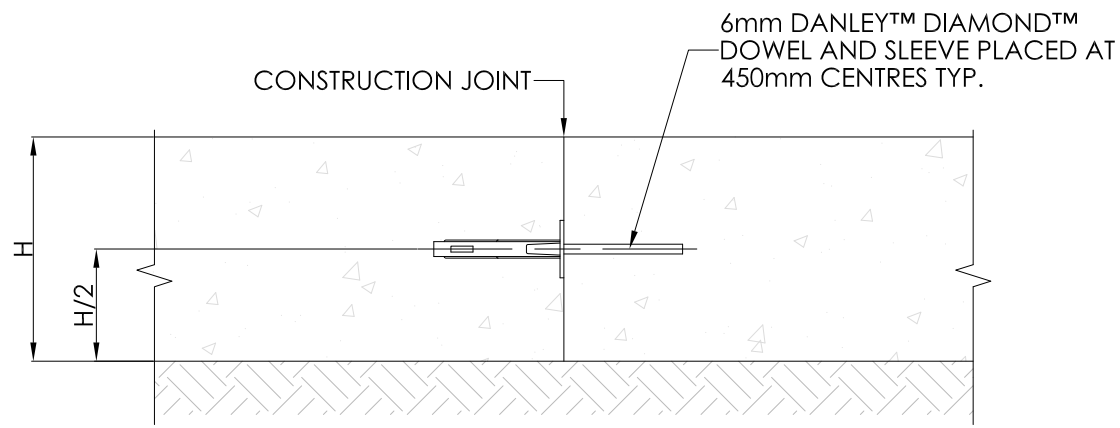

PLATE DOWEL JOINT (P.D.J.)

SCALE: 1:5

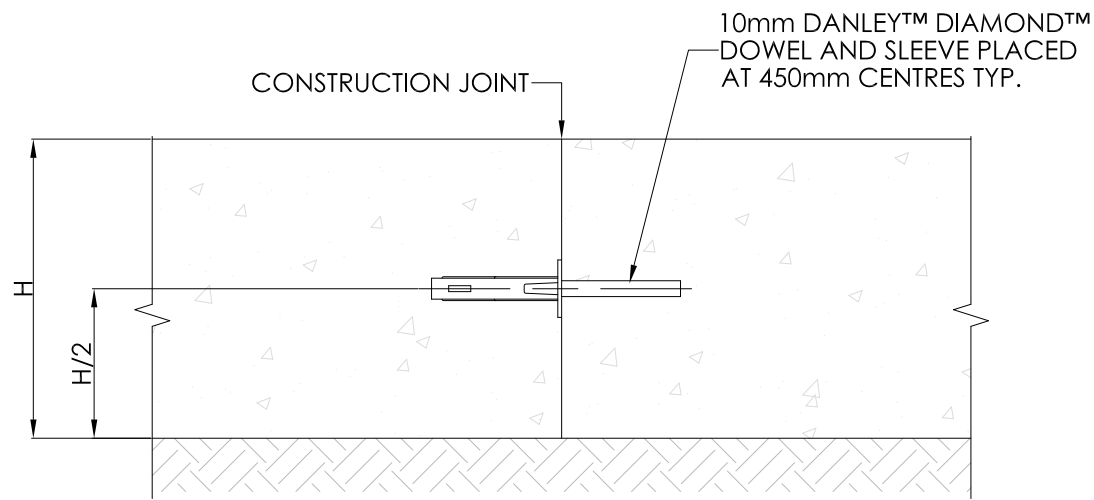

PLATE DOWEL JOINT (P.D.J.)

SCALE: 1:5

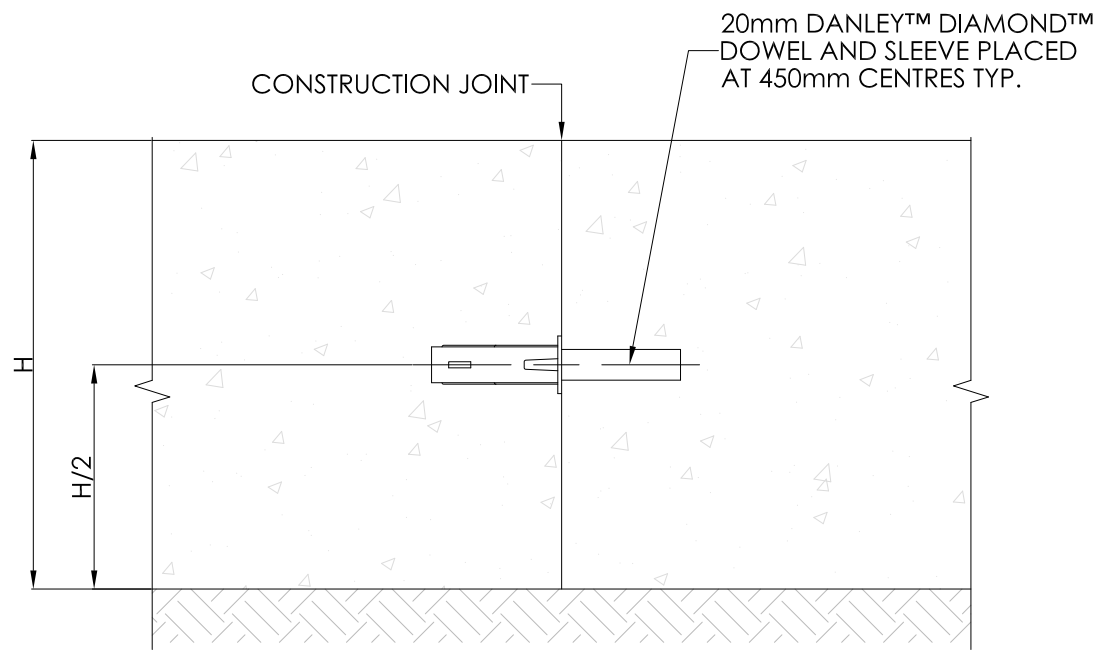

PLATE DOWEL JOINT (P.D.J.)

SCALE: 1:5

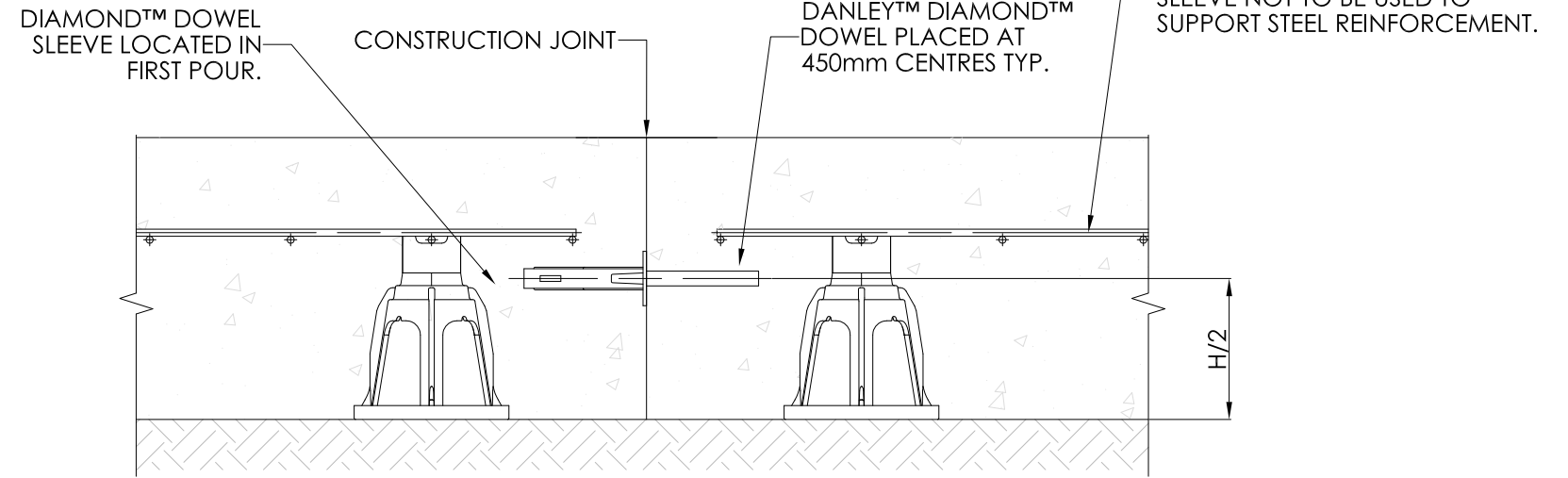

PLATE DOWEL JOINT (P.D.J.)

SCALE: 1:5

NOTE FOR SPECIFIER: NOT TO BE INCLUDED IN CONSTRUCTION DRAWINGS
 THIS IS A TYPICAL MESH REINFORCEMENT PLACEMENT DETAIL. ALTERNATE DESIGN METHODS INCORPORATING DIFFERING MESH PLACEMENT CAN BE USED IN PLACE OF THIS DETAIL AT THE DISCRETION OF THE ENGINEER. FOR FURTHER INFORMATION REGARDING ALTERNATIVE ACCEPTABLE JOINT DETAILS, PLEASE CONTACT YOUR LOCAL DANLEY REPRESENTATIVE.

GENERAL NOTES:
DIAMOND™ DOWEL DANLEY™ DIAMOND™ TAPERED PLATE DOWEL (GRADE 300, AS/NZS 3679) PROVIDING BILATERAL MOVEMENT EQUAL TO JOINT OPENING AND WITH EXPANSION CAPABILITY; THE NON-COMPRESSIBLE SLEEVE LIMITING DIFFERENTIAL DEFLECTION. AVAILABLE IN 6mm & 10mm IN BLACK, GALV. OR STAINLESS. AVAILABLE IN 20mm IN GALV.

ramsetreid
 innovative construction solutions

DANLEY™

21 STEEL PLACE, MORNINGSIDe, QLD, 4170.
 A DIVISION OF ITW AUSTRALIA PTY. LTD.

TEL: 1300 DANLEY (1300 326 539) FAX: (07) 3899 1733
 EML:sales@danley.com.au
 WEB: www.danley.com.au

THE INFORMATION CONTAINED IN THIS DRAWING IS THE SOLE PROPERTY OF RAMSREID (ITW) AUSTRALIA.

DO NOT SCALE THIS DRAWING.

DESCRIPTION: DIAMOND™ DOWEL SECTIONAL VIEWS			
SIGNED:	DRAWN: GMASON	VERIFIED: KSTORER	APPROVED: GTAYLOR
DATE:	09/04/20	09/04/20	09/04/20
CAD FILE: DAN-DWG-009 - Diamond™ Dowel Sectional Views			
DRAWING NO: DAN-DWG-009		SCALE: 1:5	REVISION: 1
SHEET: 1 OF 2		SIZE: A3	